

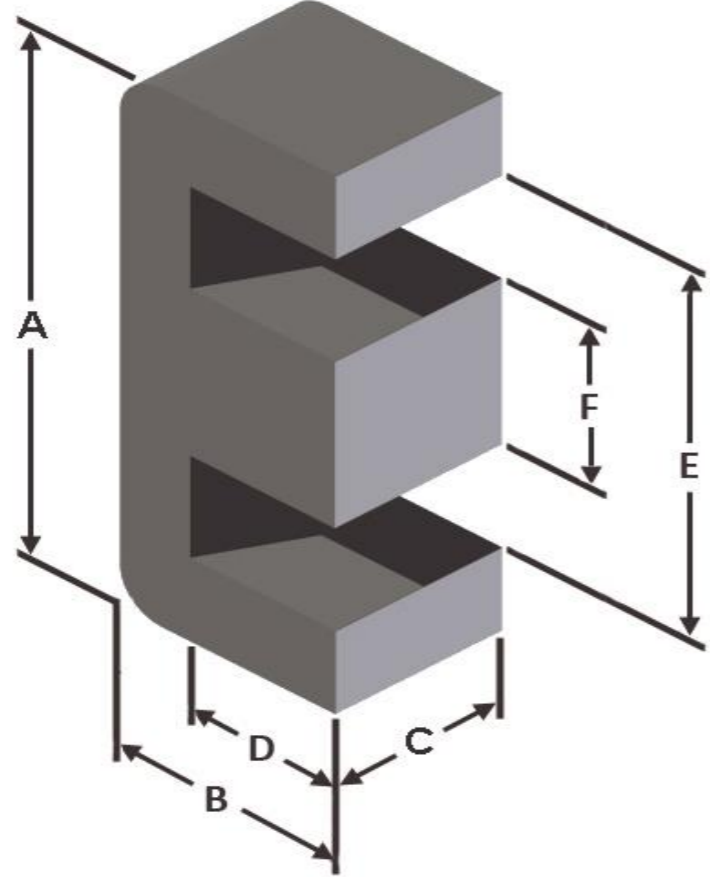

Part Number: EFS-1205532-060

Revision 20160816 - Generated 2016-Aug-16



A	120 ± 1.80 mm	4.724 ± 0.071 in
B	55 ± 0.79 mm	2.165 ± 0.031 in
C	31.5 ± 0.64 mm	1.240 ± 0.025 in
D	34.5 mm (min.)	1.358 in (min.)
E	80.4 mm (min.)	3.165 in (min.)
F	39.6 ± 0.71 mm	1.559 ± 0.028 in
Mass	(approximate)	1,030 grams/half
Magnetic Dimensions	A _e - Eff. Mag. Cross Section	12.152 cm ²
	L _e - Eff. Mag. Path Length	24.38 cm
	V _e - Eff. Core Volume	318 cm ³
	WA - Min. Eff. Window Area	13.8 cm ²
	sa - Surface Area	470 cm ²
	mlt - mean length per turn	22.4 cm
Inductance	μ _i (reference)	60
	A _L value (nominal)	482 nH/N ²
	Test Winding	N=100, #14 AWG
	Frequency	10 kHz
	Voltage on Agilent 4284A	5.4 V
	A _L tolerance	±8%
Core Loss	$\text{Core Loss (mW/cm}^3\text{)} = \frac{f}{\frac{a}{B_{pk}^3} + \frac{b}{B_{pk}^{2.3}} + \frac{c}{B_{pk}^{1.65}}} + d \cdot B_{pk}^2 \cdot f^2$	
	where B _{pk} expressed in gauss, f expressed in hertz, and: a=6.42E+08, b=3.00E+08, c=1.69E+06, d=5.56E-14	
	B _{pk}	1000 G
	frequency	50 kHz
	Core Loss (nominal)	1,011 mW/cm ³
Core Loss (maximum)	1,163 mW/cm ³	
DC Saturation	$\% \mu_i = \frac{1}{a + b \cdot H^c} + d$	
	where H expressed in oersteds, and: a=0.01, b=4.41E-06, c=1.57, d=14.29	
	H _{DC}	100 Oe
	Percent Initial Perm(nom.)	70.5%
Percent Initial Perm(min.)	64.8%	
Coating/Pkg	Coating Type:	None
	Voltage Breakdown (min.)	N/A
	Limit	N/A
	Package Quantity	16 Halves/Box

Winding Table	Wire Size	AWG	8	10	12	14	16	18	20	22	24	26	28
		mm	3.150	2.500	2.000	1.600	1.250	1.000	0.800	0.630	0.500	0.400	0.315
	Full Winding	Turns	75	115	179	276	428	662	1,025	1,587	2,456	3,801	5,882
		Rdc(Ω)	34.5 m	84.2 m	208.3 m	510.9 m	1.3	3.1	7.6	18.8	46.3	113.8	280.2

