

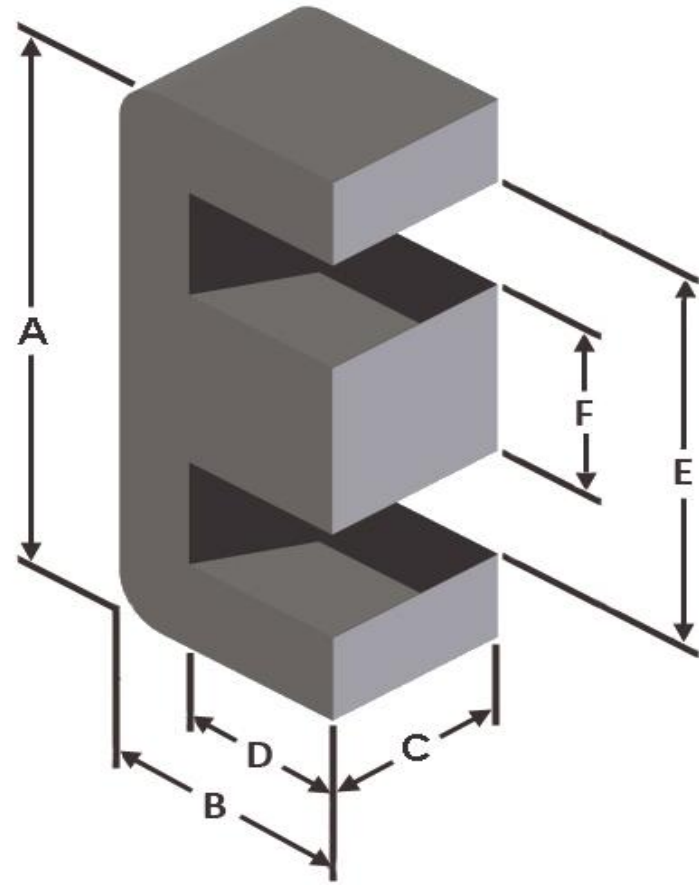

Part Number: EFS-0964226-060
Revision 20190529 - Generated 2019-May-29



A	96 ± 1.45 mm	3.780 ± 0.057 in
B	41.5 ± 0.64 mm	1.634 ± 0.025 in
C	25.5 ± 0.51 mm	1.004 ± 0.020 in
D	25 mm (min.)	0.984 in (min.)
E	64.4 mm (min.)	2.535 in (min.)
F	31.6 ± 0.64 mm	1.244 ± 0.025 in
Mass	(approximate)	470 grams/half
Magnetic Dimensions	A _e - Eff. Mag. Cross Section	8.02 cm ²
	L _e - Eff. Mag. Path Length	18.03 cm
	V _e - Eff. Core Volume	145 cm ³
	WA - Min. Eff. Window Area	8.04 cm ²
	sa - Surface Area	288 cm ²
	mlt - mean length per turn	18.0 cm
Inductance	μ _i (reference)	60
	A _L value (nominal)	391 nH/N ²
	Test Winding	N=100, #14 AWG
	Frequency	10 kHz
	Voltage on Agilent 4284A	3.6 V
	A _L tolerance	±8%
Core Loss	$\text{Core Loss (mW/cm}^3\text{)} = \frac{f}{\frac{a}{B_{pk}^3} + \frac{b}{B_{pk}^{2.3}} + \frac{c}{B_{pk}^{1.65}}} + d \cdot B_{pk}^2 \cdot f^2$	
	where B _{pk} expressed in gauss, f expressed in hertz, and: a=6.42E+08, b=3.00E+08, c=1.69E+06, d=5.56E-14	
	B _{pk}	1000 G
	frequency	50 kHz
	Core Loss (nominal)	1,011 mW/cm ³
	Core Loss (maximum)	1,163 mW/cm ³
DC Saturation	$\% \mu_i = \frac{1}{a + b \cdot H^c} + d$	
	where H expressed in oersteds, and: a=0.01, b=4.41E-06, c=1.57, d=14.29	
	H _{DC}	150 Oe
	Percent Initial Perm(nom.)	57.3%
Percent Initial Perm(min.)	51.2%	
Coating/Pkg	Coating Type:	None
	Voltage Breakdown (min.)	N/A
	Limit	N/A
	Package Quantity	24 Halves/Box

Winding Table	Wire Size	AWG	8	10	12	14	16	18	20	22	24	26	28
		mm	3.150	2.500	2.000	1.600	1.250	1.000	0.800	0.630	0.500	0.400	0.315
	Full Winding	Turns	43	67	104	161	249	385	596	922	1,428	2,210	3,420
		Rdc(Ω)	15.9 m	39.4 m	97.2 m	239.4 m	588.9 m	1.4	3.6	8.8	21.6	53.2	130.9

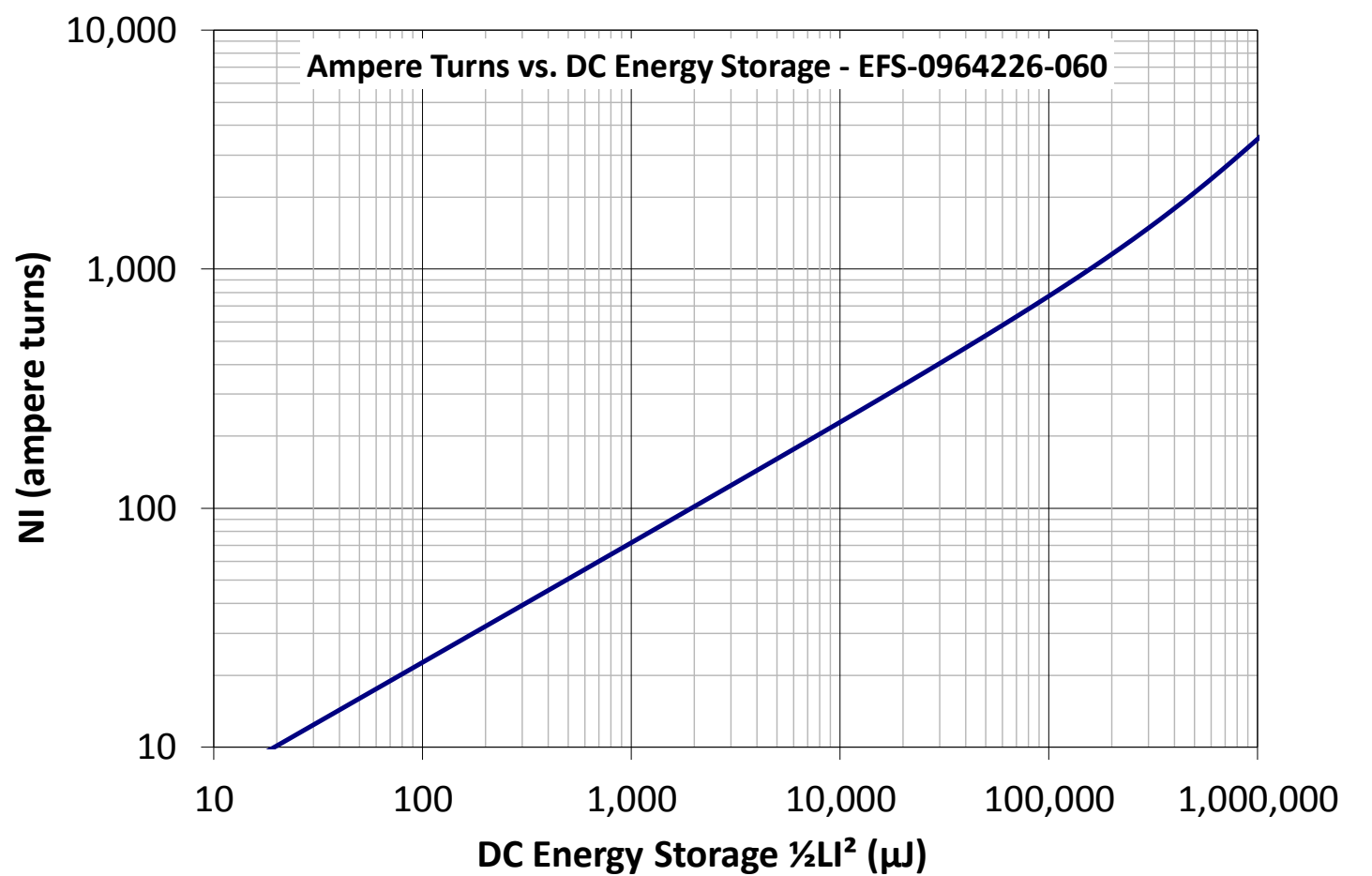
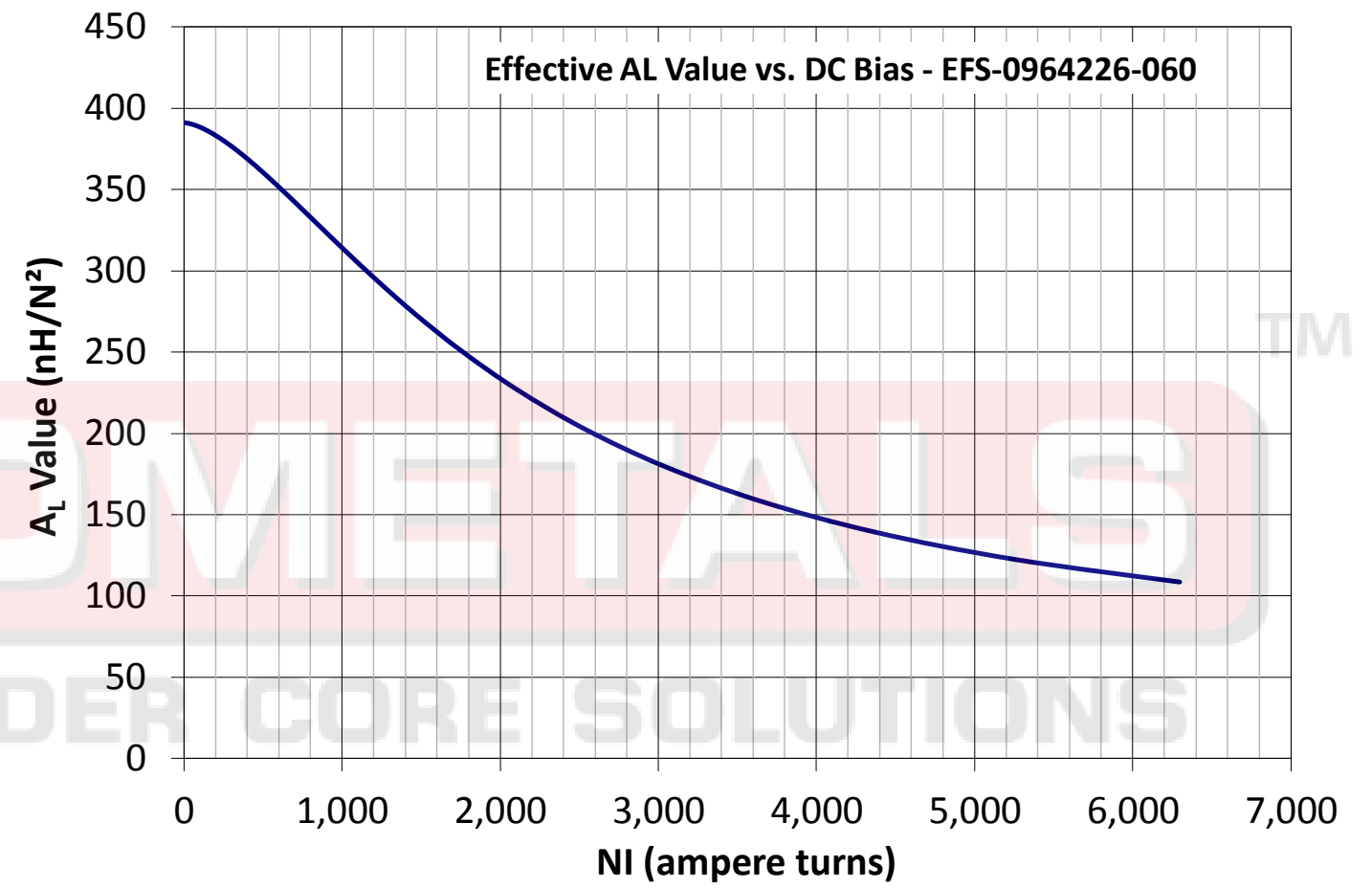
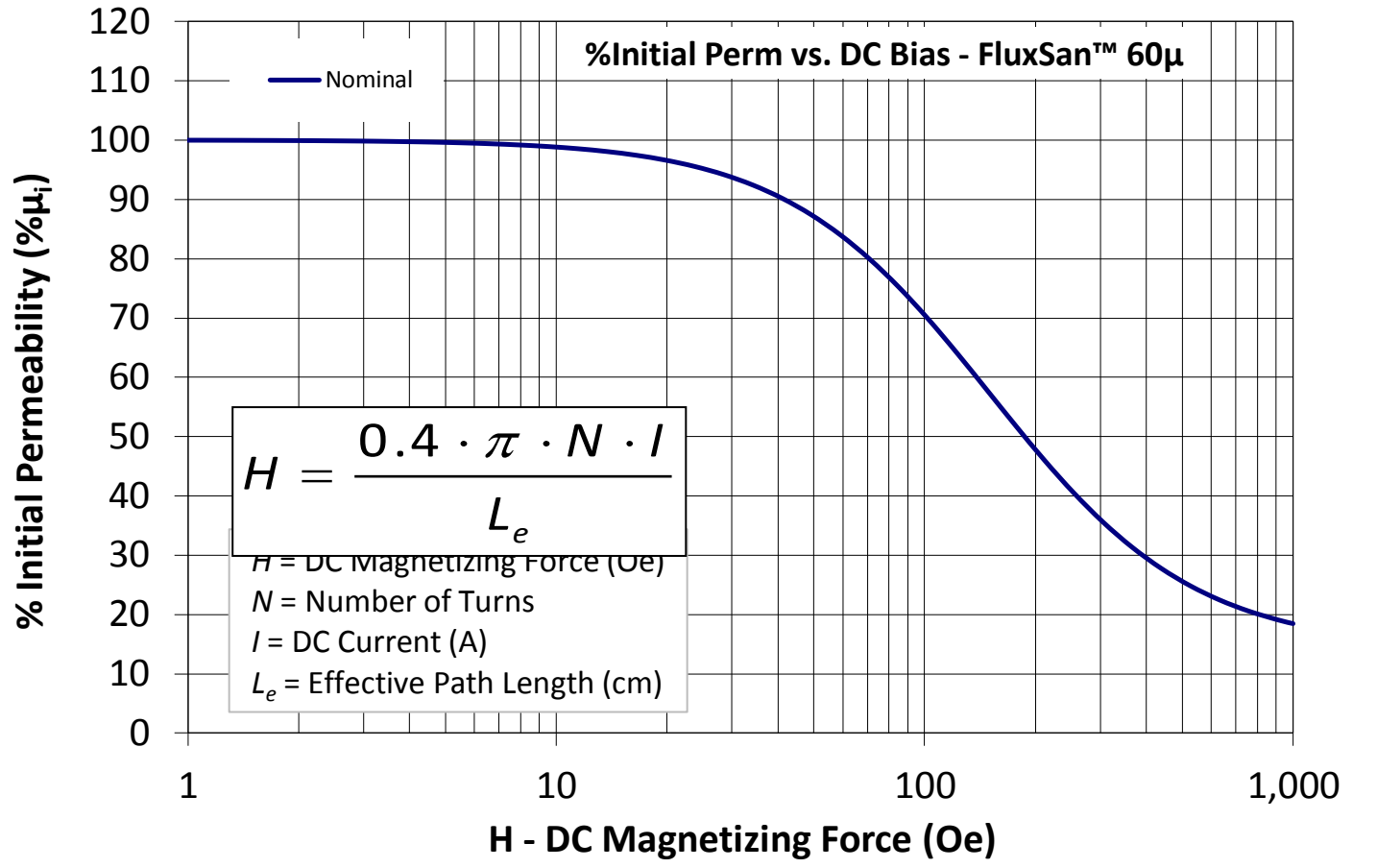
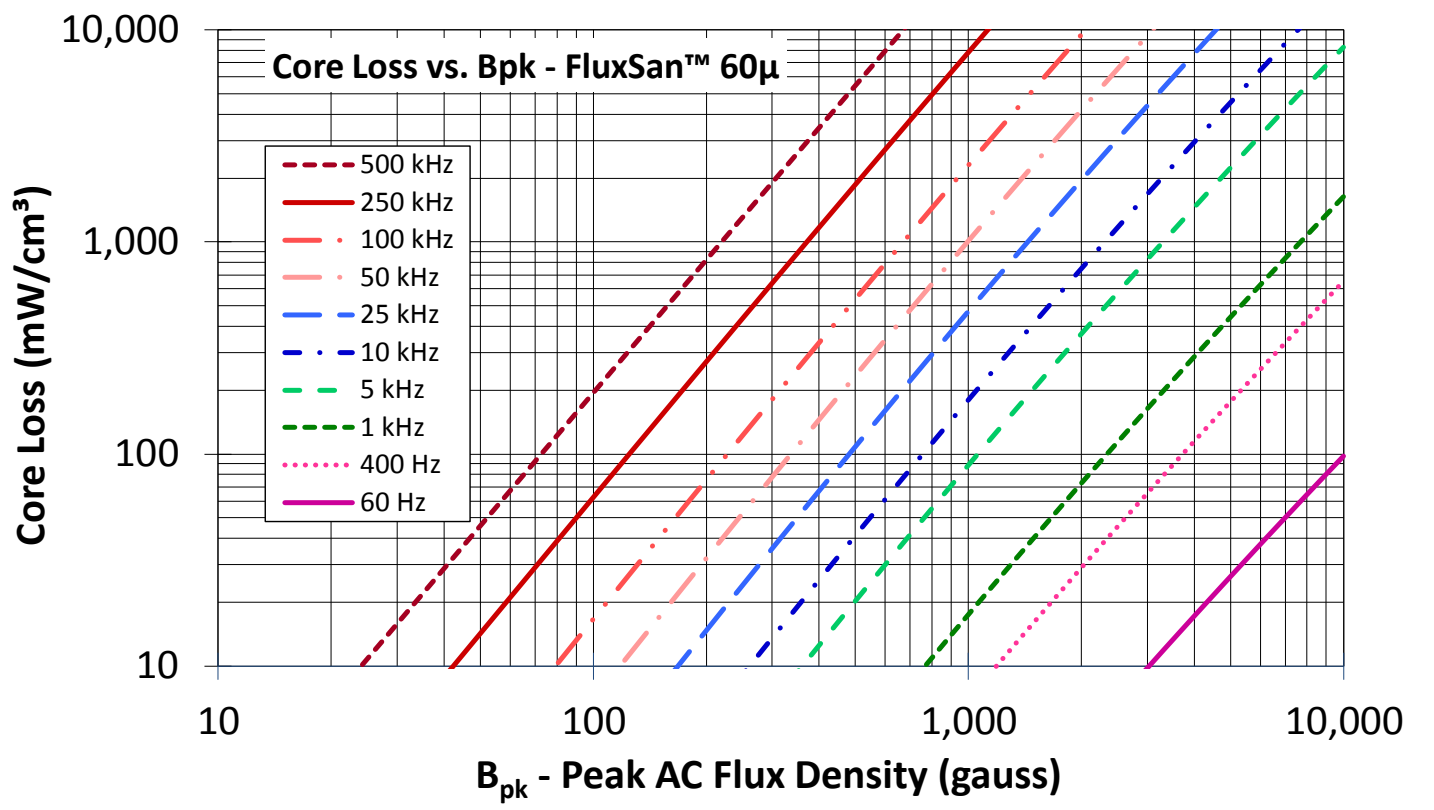

Handling and Storage: Cores should be stored in the original unopened packaging between -10°C and +50°C and less than 60% relative humidity. After the original packaging is opened, the cores should be stored between -8°C and +25°C less than 30% relative humidity. Gloves should be used when handling uncoated cores. The cores should also be sheltered from rain, moisture, salt water, salt air, plasters, ashes, sulfur, sulfur dioxide, ammonia sulfates, soils, acids, metals shavings, and solvents.

Operating Temperature: Cores can be used continuously at operating temperatures between -60°C and +200°C.

RoHS 2.0, REACH and ISO (TS16949, ISO 9001, ISO 14001) compliant. Statements available for download at www.micrometalsapc.com.