

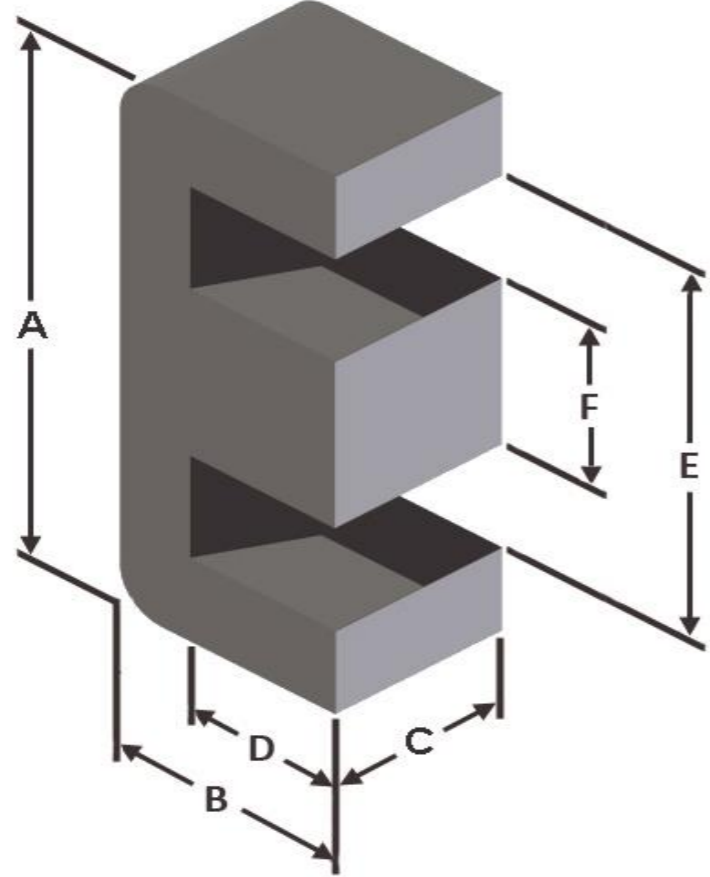

Part Number: EFS-0432111-060

Revision 20160816 - Generated 2016-Aug-16



A	42.8 ± 0.64 mm	1.685 ± 0.025 in
B	21.1 ± 0.33 mm	0.831 ± 0.013 in
C	10.8 ± 0.25 mm	0.425 ± 0.010 in
D	15 mm (min.)	0.591 in (min.)
E	30.4 mm (min.)	1.197 in (min.)
F	11.9 ± 0.25 mm	0.469 ± 0.010 in
Mass	(approximate)	41 grams/half
Magnetic Dimensions	A _e - Eff. Mag. Cross Section	1.28 cm ²
	L _e - Eff. Mag. Path Length	9.84 cm
	V _e - Eff. Core Volume	12.6 cm ³
	WA - Min. Eff. Window Area	2.74 cm ²
	sa - Surface Area	65.7 cm ²
mlt - mean length per turn	8.24 cm	
Inductance	μ _i (reference)	60
	A _L value (nominal)	105 nH/N ²
	Test Winding	N=100, #18 AWG
	Frequency	10 kHz
	Voltage on Agilent 4284A	0.57 V
A _L tolerance	±8%	
Core Loss	$\text{Core Loss (mW/cm}^3\text{)} = \frac{f}{\frac{a}{B_{pk}^3} + \frac{b}{B_{pk}^{2.3}} + \frac{c}{B_{pk}^{1.65}}} + d \cdot B_{pk}^2 \cdot f^2$	
	where B _{pk} expressed in gauss, f expressed in hertz, and: a=6.42E+08, b=3.00E+08, c=1.69E+06, d=5.56E-14	
	B _{pk}	1000 G
	frequency	50 kHz
	Core Loss (nominal)	1,011 mW/cm ³
Core Loss (maximum)	1,163 mW/cm ³	
DC Saturation	$\% \mu_i = \frac{1}{a + b \cdot H^c} + d$	
	where H expressed in oersteds, and: a=0.01, b=4.41E-06, c=1.57, d=14.29	
	H _{DC}	100 Oe
	Percent Initial Perm(nom.)	70.5%
Percent Initial Perm(min.)	64.8%	
Coating/Pkg	Coating Type:	None
	Voltage Breakdown (min.)	N/A
	Limit	N/A
	Package Quantity	210 Halves/Box

Winding Table	Wire Size	AWG	8	10	12	14	16	18	20	22	24	26	28
		mm	3.150	2.500	2.000	1.600	1.250	1.000	0.800	0.630	0.500	0.400	0.315
	Full Winding	Turns	15	23	35	55	85	131	203	314	486	752	1,164
	Rdc(Ω)	2.5 m	6.2 m	15.0 m	37.5 m	92.1 m	225.8 m	556.5 m	1.4	3.4	8.3	20.4	

