

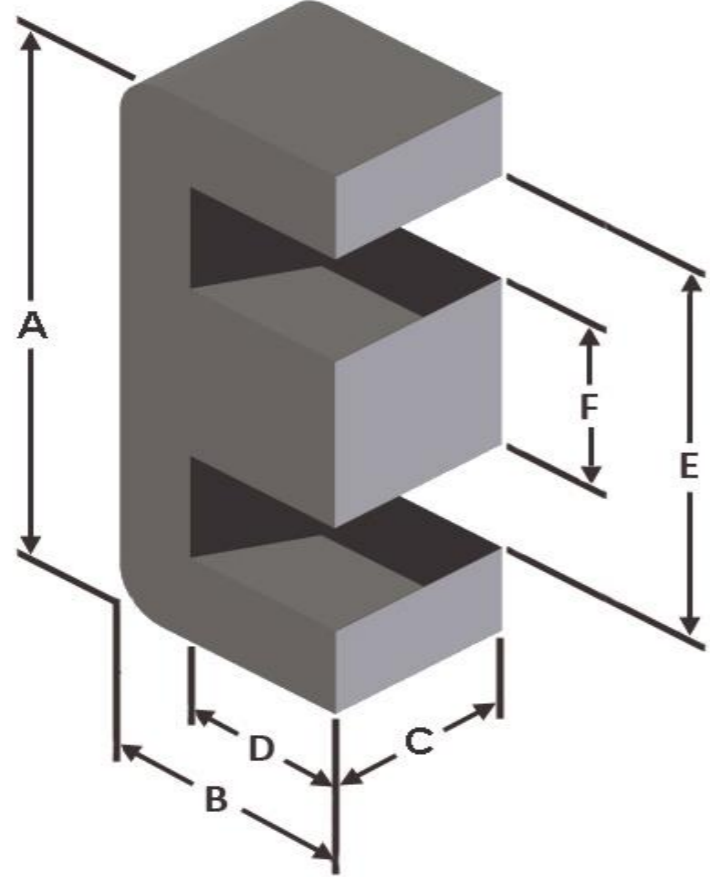

**Part Number:** EFS-0301507-026

Revision 20160816 - Generated 2016-Aug-16



<b>A</b>	30.1 ± 0.46 mm	1.185 ± 0.018 in
<b>B</b>	15.01 ± 0.23 mm	0.591 ± 0.009 in
<b>C</b>	7.06 ± 0.15 mm	0.278 ± 0.006 in
<b>D</b>	9.7 mm (min.)	0.382 in (min.)
<b>E</b>	19.5 mm (min.)	0.768 in (min.)
<b>F</b>	6.96 ± 0.20 mm	0.274 ± 0.008 in
<b>Mass</b>	(approximate)	12 grams/half
<b>Magnetic Dimensions</b>	A <sub>e</sub> - Eff. Mag. Cross Section	0.601 cm <sup>2</sup>
	L <sub>e</sub> - Eff. Mag. Path Length	6.56 cm
	V <sub>e</sub> - Eff. Core Volume	3.94 cm <sup>3</sup>
	WA - Min. Eff. Window Area	1.20 cm <sup>2</sup>
	sa - Surface Area	31.4 cm <sup>2</sup>
	mlt - mean length per turn	5.31 cm
<b>Inductance</b>	μ <sub>i</sub> (reference)	26
	A <sub>L</sub> value (nominal)	40 nH/N <sup>2</sup>
	Test Winding	N=100, #22 AWG
	Frequency	10 kHz
	Voltage on Agilent 4284A	0.27 V
	A <sub>L</sub> tolerance	±8%
<b>Core Loss</b>	$\text{Core Loss (mW/cm}^3\text{)} = \frac{f}{\frac{a}{B_{pk}^3} + \frac{b}{B_{pk}^{2.3}} + \frac{c}{B_{pk}^{1.65}}} + d \cdot B_{pk}^2 \cdot f^2$	
	where B <sub>pk</sub> expressed in gauss, f expressed in hertz, and: a=1.00E+06, b=1.70E+08, c=3.12E+06, d=6.33E-14	
	B <sub>pk</sub>	300 G
	frequency	100 kHz
	Core Loss (nominal)	225 mW/cm <sup>3</sup>
Core Loss (maximum)	258 mW/cm <sup>3</sup>	
<b>DC Saturation</b>	$\% \mu_i = \frac{1}{a + b \cdot H^c} + d$	
	where H expressed in oersteds, and: a=0.01, b=1.17E-06, c=1.58, d=27.84	
	H <sub>DC</sub>	200 Oe
	Percent Initial Perm(nom.)	80.8%
Percent Initial Perm(min.)	76.4%	
<b>Coating/Pkg</b>	Coating Type:	None
	Voltage Breakdown (min.)	N/A
	Limit	N/A
	Package Quantity	360 Halves/Box

<b>Winding Table</b>	<b>Wire Size</b>	AWG	12	14	16	18	20	22	24	26	28	30	32
		mm	2.000	1.600	1.250	1.000	0.800	0.630	0.500	0.400	0.315	0.250	0.200
	<b>Full Winding</b>	Turns	15	24	37	57	89	137	212	329	509	788	1,219
	Rdc(Ω)		4.1 m	10.5 m	25.9 m	63.3 m	157.3 m	385.1 m	947.7 m	2.3	5.8	14.2	34.9

